

# *MICROSYNC*

## User Manual



TIMING AND SPORT

Microgate s.r.l.

Via Stradivari, 4 Stradivaristr.  
39100 BOLZANO - BOZEN  
ITALY

## Contents

<b>1. INTRODUCTION</b> .....	<b>3</b>
<b>2. DESCRIPTION</b> .....	<b>4</b>
<b>3. SWITCHING ON/OFF</b> .....	<b>5</b>
<b>4. BASIC USE</b> .....	<b>6</b>
<b>5. SYNCHRONIZING REI2 USING THE CAB146 CABLE</b> .....	<b>7</b>
<b>6. MANUAL MODE</b> .....	<b>8</b>
6.1. Synchronizing MicroSync .....	8
6.2. Synchronizing other devices.....	9
<b>7. BATTERY RECHARGE</b> .....	<b>10</b>
<b>8. SATELLITE SIGNAL</b> .....	<b>11</b>
<b>9. CONFIGURATION PARAMETERS</b> .....	<b>12</b>
<b>10. CONNECTIONS</b> .....	<b>15</b>
10.1. Banana jacks .....	15
10.1.1. The signal in output.....	15
10.1.2. The signal in input.....	15
10.2. Amphenol socket.....	15
<b>11. MAINTENANCE, AMBIENT CONDITIONS AND WARNINGS REGARDING USE</b> .	<b>17</b>
11.1. Cleaning.....	17
11.2. Ambient conditions .....	17
11.3. Attention.....	17
<b>12. TECHNICAL DATA</b> .....	<b>18</b>
<b>13. CHANGE HISTORY</b> .....	<b>19</b>

## Figures.

Fig. 1 – Overview.....	4
Fig. 2 – signal in output. ....	15
Fig. 3 –Amphenol socket connector .....	15

## 1. Introduction

MicroSYNC is the state-of-the-art in synchronizers. Inside its compact container is a GPS receiver able to guarantee synchronization accuracy of  $\pm 1\mu\text{s}$  in relation to UTC time and a 1 ppm heat-compensated internal time base able to ensure the possibility of synchronization even when there is no satellite signal.

As well as showing the time currently set in the synchronizer, the display with 2 16-character lines makes it possible to view the time of its next synchronization signal and to view its status, and allows easy configuration of work parameters. Thanks to backlighting it can also be used when visibility is poor.

Simplicity of use was one of Microgate's aims in the device's design. The operations required are switching it on, waiting for the appearance of the signal indicating GPS synchronization and connecting the cables to synchronize the external device. In combination with the REI2 stopwatch, it provides a system with an accuracy that had hitherto been inconceivable, keeping the internal time base synchronized with the UTC signal.

In this manual the keys to press are shown between angled brackets, for example, press **<ENT>** means press the key with ENT on it, while the options suggested by MicroSYNC are shown in bold.

In the display illustrations, a time written in *italics* means that that time is running on the synchronizer.

An underlined figure indicates that the blinking cursor is in that position and the MicroSync is waiting for an input.

This manual is for firmware version 00001.

## 2. Description

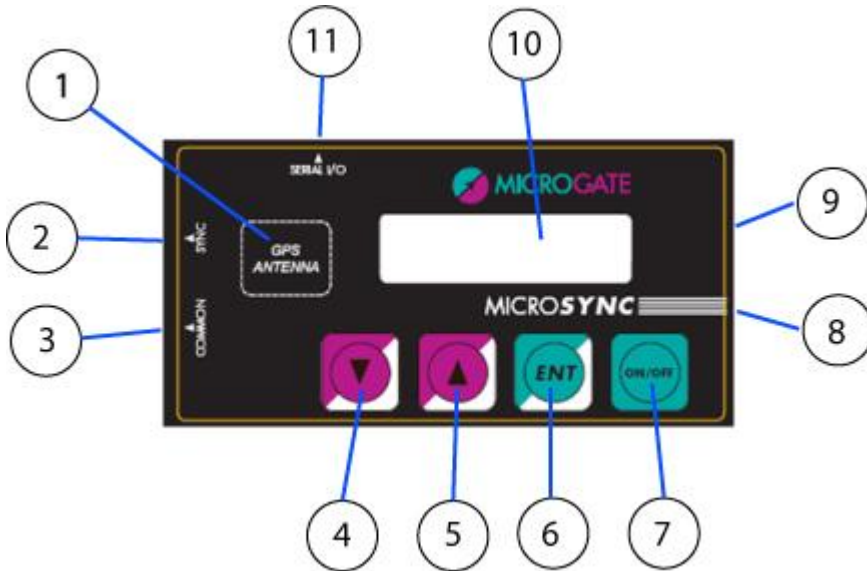

Fig. 1 – Overview

1. Position of GPS antenna
2. SYNC: green banana jack
3. COMMON: black banana jack
4. UP ARROW key
5. DOWN ARROW key
6. ENT key
7. ON/OFF key
8. Low battery and recharge status LED
9. Recharge jack socket
10. 2 line x 16 character alphanumeric display
11. I/O SERIAL: 6-pole Amphenol socket

### 3. Switching on/off

To switch on the synchronizer, press the <**ON/OFF**> key for about a second. The display lights up and the serial number and the firmware version installed appear on the display.

```
Serial:  xxxxx  
Version: xxxxx
```

When switched on, MicroSync shows the time 00:00:00 and waits to receive a signal from the GPS satellites or external synchronization.

```
MicroSync  
00:00:00
```

To switch off the MicroSync keep the <**ON/OFF**> key pressed down until the words **Good bye** appear on the display. As soon as the <**ON/OFF**> key is released, the synchronizer switches off.

```
Good bye.
```

The device switches off automatically when the battery charge level reaches the minimum level, briefly showing the words **Battery low – Good bye**.

```
Battery low  
Good bye.
```

To activate lighting up of the display, briefly press any key. The display stays lit up for about 1 minute.

## 4. Basic use

To synchronize your stopwatch, whether it is a Microgate REI2 or a RaceTime2, or to synchronize the devices of other producers, follow the instructions given below:

Operation	On the display appears:
Switch on the synchronizer with the <ON/OFF> key	<div style="border: 1px solid black; padding: 2px; background-color: #e0f7fa;">           Serial: xxxxx            Version: xxxxx         </div>
The internal time is shown on the display	<div style="border: 1px solid black; padding: 2px; background-color: #e0f7fa;">           MicroSync            00:00:00         </div>
Position the synchronizer so that there are no obstacles between it and the sky	
Wait until running time appears on the display	<div style="border: 1px solid black; padding: 2px; background-color: #e0f7fa;">           MicroSync            10:12:05         </div>
<b>Connect the device to be synchronized to the synchronizer using banana jack sockets (see Fig. 1 – Overview on p. 4)</b>	
Press the <ENT> key to view the next synchronization time	<div style="border: 1px solid black; padding: 2px; background-color: #e0f7fa;">           MicroSync            10:13:00         </div>
Set the synchronization time on the device and wait for the impulse to be sent	

The time of the next synchronization depends on the parameter selected in the synchronization parameters.

The time indicated by the synchronizer may differ from the real time until the correct time zone is set. This in no way affects the accuracy of the seconds shown on the display or the generation of the signal at  $\pm 1 \mu\text{s}$  in relation to UTC time.

For operational details consult the operational notes for the various devices provided by the respective producers.

## 5. Synchronizing REI2 using the CAB146 cable

By using the dedicated synchronization cable it is possible to acquire UTC time on the REI2 directly from the synchronizer. To do this follow the instructions below:

Operation	On the display appears:
Switch on the synchronizer with the <ON/OFF> key	<pre>Serial: xxxxx Version: xxxxx</pre>
The internal time is shown on the display	<pre>MicroSync 00 :00 :00</pre>
Position the synchronizer so that there are no obstacles between it and the sky	
Wait until running time appears on the display	<pre>MicroSync 10:12:05</pre>
Connect the synchronizer to the REI2 using the CAB146 cable	
Access the REI2 <b>Synchronization</b> menu and select the desired mode for synchronization with MicroSync	
Wait until the REI2 internal clock synchronizes itself with the GPS signal	
If Base <b>GPS</b> has not been selected on the REI2, disconnect the synchronizer, otherwise keep it connected to the REI2.	

See the chapter Synchronization of the various REI2 manuals for detailed operational instructions for the REI2.

## 6. Manual mode

It is possible to use MicroSync to supply a synchronization signal that is not aligned with the UTC system provided by the GPS system. To do this it is first necessary to synchronize the MicroSync.

### 6.1. Synchronizing MicroSync

To synchronize MicroSync do as follows:

Operation	On the display appears:
Switch on the synchronizer with the <ON/OFF> key	Serial: xxxxx Version: xxxxx
The internal time is shown on the display	MicroSync 00:00:00
Keep the keys <Up arrow> and <Down arrow> pressed down together until the words <b>Entering setup</b> appear	Entering setup
The words <b>Setup timezone</b> appear on the display	Setup time zone
press the <Up arrow> key ...	Setup sync period
press the <Up arrow> key ...	
...until the words <b>Set manual mode</b> appear	Set manual mode
press the <ENT> key	
the time begins to blink	Set sync time <u>00</u> :00:00
Press the <Up arrow> key to increase its value or <Down arrow> to decrease it and confirm the value with <ENT>	
The tenths of a minute begin to blink	Set sync time 10: <u>00</u> :00
Correct the value with the <Arrow> keys and confirm with <ENT>	
Repeat the same procedure with the minutes, tenths of a second and seconds	Set sync time 10:10: <u>00</u>
When the seconds value has been confirmed, the words <b>Waiting for sync</b> appear	Waiting for sync

Operation	On the display appears:
In this way the synchronizer sets itself up to wait for the synchronization impulse on the banana jack sockets	
Connect the MicroSync to the synchronizing device using the banana jack sockets	
When the synchronization impulse is received, a beep is emitted and the words <b>External sync done</b> appear	<div style="border: 1px solid black; padding: 2px; display: inline-block;">           External sync done         </div>

At any moment the procedure can be abandoned by pressing the <ON/OFF> key.

## 6.2. Synchronizing other devices

Operation	On the display appears:
Now your synchronizer is ready to supply the synchronization signal to other devices	<div style="border: 1px solid black; padding: 2px; display: inline-block;">           MicroSync 10:12:05         </div>
Connect the device to be synchronized to the synchronizer using the banana jack sockets	
Press the <ENT> key to view the next time for synchronization	<div style="border: 1px solid black; padding: 2px; display: inline-block;">           MicroSync 10:13:00         </div>
Set the synchronization time on the device and wait for the impulse to be sent	



During manual mode functioning the precision provided is that of the internal time base and not the far more precise one of the GPS time base.

## 7. Recharging the batteries

To recharge the batteries you need only plug a power supply voltage of 9 to 20V into the appropriate jack socket (see Fig. 1). Recharge starting with completely flat batteries lasts about 3 hours.

We advise you to keep MicroSync switched off while charging, using the dedicated Microgate adaptors.

“Low battery” is signal LED on the display by the blinking battery symbol and the blinking red LED.

The device can also function if powered externally, once again using the recharge jack socket with voltages of 9 to 20V. In this case the built-in battery is constantly recharged in order to keep it at least 90% charged.

The battery symbol that fills up at the bottom right of the display shows recharging is in progress.

At any moment it is possible to find out the recharge status of the batteries by pressing and immediately releasing the <ON/OFF> key. On the display the status of the remaining charge is shown as a percentage.

```
Battery: xx%  
Satellites: x
```

The LED indicates the status of the batteries and of the recharge voltage:

- Red: battery almost flat, remaining autonomy less than 20%
- Orange: presence of external power supply and recharge in progress
- Green: battery recharge completed

The built-in batteries do not suffer from memory effect so it is possible to recharge the device at any moment.



The Li-ion batteries used by MicroSync have a longer working life if they are frequently charged.

## 8. Satellite signal

Reception of the satellite signal is necessary to guarantee a precision of  $\pm 1 \mu\text{s}$  in relation to the UTC signal and for synchronization of the internal time base.

Confirmation of correct satellite signal reception is indicated by the antenna symbol at the bottom right of the display.

The synchronizer waits to receive the signal from at least 4 satellites before linking its time base to the UTC time base. When the internal time base has been aligned to that of the clocks of the GPS satellites, it is kept aligned by means of the PPS signal received once a second. The maximum deviation between the synchronizer and the UTC time base is  $\pm 1 \mu\text{s}$  (1/1.000.000 s).

The stability of the time base aligned with the GPS system is not affected either by climatic conditions or by ageing of the device.

If the satellite signal is lost, the antenna signal begins to blink. If the signal does not return in sufficient time to guarantee the maintenance of maximum precision, the antenna symbol disappears.

At any moment it is possible to find out the number of satellites received by briefly pressing the <ON/OFF> key. The word **Satellites:** precedes the number of satellites currently being received.

```
Battery: xx%  
Satellites: x
```

The satellite signal is not received inside tunnels and other underground environments. Reception is difficult inside buildings. In the latter case, the synchronizer should be placed near a window.

Do not place anything on the synchronizer to avoid blocking the satellite signal.

## 9. Configuration parameters

MicroSync makes it possible to set several function parameters.

These are:

- **Timezone:** to set the time zone in which you are situated.
- **Delay DCF77:** to set a delay of 76ms in relation to the official UTC second 0 for compatibility with some synchronizers that are based on the DCF77 radio time signal.
- **NMEA output:** Enables or disables the transmission of NMEA data on the serial port. The transmission speed is 9600 bps – no parity – no control protocol.
- **Manual mode:** allows configuration of the synchronizer in non-GPS mode. See relative notes.
- **Sync period:** to select the frequency with which the synchronization signal is generated. The possible options are 10 minutes, 60, 30 or 10 seconds and manual sync. If the value 10 minutes is selected, the synchronizer generates the signal at 0, 10, 20, 30, 40 and 50 minutes of each hour. If 60 s is selected, the signal is generated when the full minute is up, if 30 s is selected, the signal is generated at 0 and 30 seconds of each minute, if 10 s is selected, the signal is generated at 0, 10, 20, 30, 40 and 50 seconds of each minute. If **Manual sync** is chosen, the signal is generated at exactly 5 seconds after the **<arrow>** key is released.

To set the various parameters, follow the instructions below:

Operation	On the display appears:
To configure the synchronizer, press the keys <b>&lt;Down arrow&gt;</b> and <b>&lt;Up arrow&gt;</b> together until the words <b>Entering setup</b> appear	Entering setup
Release the keys	Setup timezone
If you wish to set the time zone, press <b>&lt;ENT&gt;</b> , otherwise press <b>&lt;Down arrow&gt;</b> again	
select with <b>&lt;Up arrow&gt;</b> to increase the time zone value or with <b>&lt;Down arrow&gt;</b> to decrease it.	Setup timezone timezone: <u>x</u>
Confirm the value set with <b>&lt;ENT&gt;</b> . After displaying the words <b>Timezone saved ...</b>	Timezone saved
...Microsync returns to operational mode.	MicroSync HH:MM:SS
The serial number and firmware version are displayed	Serial: xxxxx Version: xxxxx
<b>&lt;Down arrow&gt;</b>	

Operation	On the display appears:
In order not to manage the 76 ms delay in relation to the UCT 0, press <b>&lt;Down arrow&gt;</b>	xxxxxxx DCF77 delay
If the delay was not enabled, it is possible to enable it	Enable DCF77 delay
Press <b>&lt;ENT&gt;</b> to enable it and ...	Delay DCF77 enabled
...Microsync returns to operational mode.	MicroSync D=76ms HH:MM:SS
If the delay was enabled, it is possible to disable it	Disable DCF77 delay
Press <b>&lt;ENT&gt;</b> to disable it and ...	Delay DCF77 disabLED
...Microsync returns to operational mode.	MicroSync HH:MM:SS
<b>&lt;Down arrow&gt;</b>	
In order not to manage the NMEA data output, press <b>&lt;Down arrow&gt;</b>	xxxxxxx NMEA output
If the NMEA data output was not enabled, it is possible to enable it	Enable NMEA output
Press <b>&lt;ENT&gt;</b> to enable it and ...	NMEA output enabLED
...Microsync returns to operational mode.	MicroSync HH:MM:SS
If the NMEA data output was enabled, it is possible to disable it	Disable NMEA output
Press <b>&lt;ENT&gt;</b> to disable it and ...	NMEA output disabLED
...Microsync returns to operational mode.	MicroSync HH:MM:SS
<b>&lt;Down arrow&gt;</b>	Set manual mode

Operation	On the display appears:
If you wish to pass to manual mode, press <ENT>, otherwise press <Down arrow>	Set manual mode
For details see chap. 6 Manual mode on p. 8	
<Down arrow>	
To set the frequency with which the synchronization signal is generated, press <ENT>, otherwise press the <Down arrow> key to return to timezone setup.	Setup sync period
Press the <Up arrow> key to increase the gap between one impulse and the next, <Down arrow> to reduce it.	Set sync period xx xxx
After selecting the desired frequency, press <ENT> to confirm and ...	Sync period saved
...Microsync returns to operational mode.	MicroSync HH:MM:SS

The configuration parameters may be scrolled in sequence by using either the <Up arrow> key or a combination of the two <Arrow> keys.

Parameter	Value	Description
Timezone	From -12 to +12	Specifies the time zone in relation to Greenwich time.
---		Information about the MicroSync
DCF77 delay	Enable / Disable	Delays the output signal by 76 ms in relation to UTC 0.
NMEA output	Enable / Disable	Enables transmission of NMEA data on the serial port
Manual mode		Enables non-GPS manual mode
Sync period	10 min, 60 s, 30 s, 10 s, manual sync	Sets the gap with which the synchronization signal is generated.

## 10. Connections

MicroSync has 4 connections: 2 banana jack sockets for the synchronization signal, an Amphenol socket for direct connection to the REI2 or Pc and a jack socket for recharging.

### 10.1. Banana jacks

MicroSync gives a normally open output signal that is brought to the reference level (through the COM socket, BLACK banana jack) at the moment of synchronization. The signal is sent on the green banana jack (SYNC).

#### 10.1.1. The signal in output

The output level passes from high to low and is kept low for about 686.1 ms.

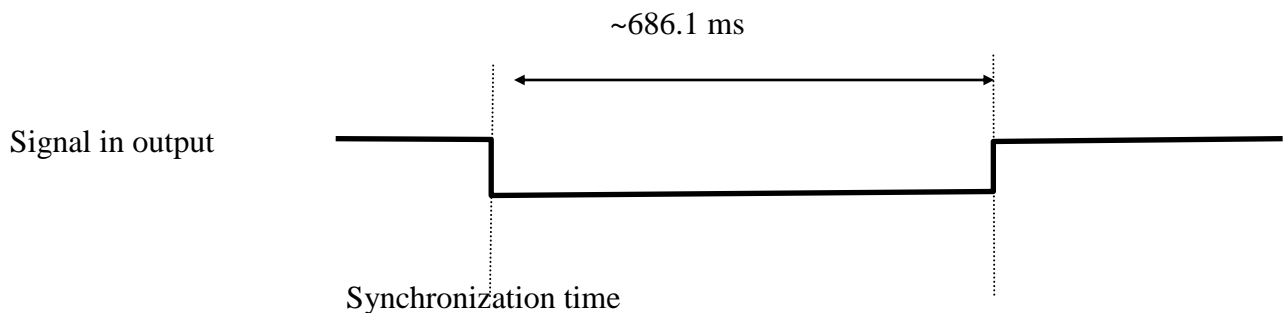

Fig. 2 – signal in output.

#### 10.1.2. The signal in input

To manually synchronize the synchronizer if a GPS signal is not available, bring the value on the green banana jack to the COM reference level using a button or another synchronizer.

### 10.2. Amphenol socket

This type of connector is the Microgate serial standard and conforms to the following regulatory convention:

6 pole Amphenol socket 240° signal standard RS232 – contact side view.

Pole n°	Description
1	Serial output (TXD)
2	3,3V regulated output, max 100mA
3	RS232 input for flow control (CTS)
4	RS232 output for flow control (RTS)
5	Earth (GND)
6	Serial input (RXD)

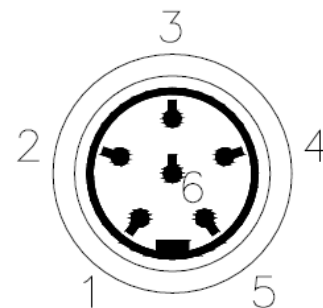

Fig. 3 –Amphenol socket connector

The synchronization signal is repeated on the Amphenol socket bringing the voltage value of pin 4 to the GND reference level (pin 5).

The use of the synchronization signal on the Amphenol port is reserved for use with the Microgate REI2 stopwatch.



Do not use this signal if the DCF77 delay is enabled.

## 11. Maintenance, ambient conditions and warnings regarding use

The only maintenance operations the user can perform are battery recharge and any external cleaning necessary.

Under no circumstances should the device be opened on pain of forfeiture of the guarantee. In any case, no internal part can be maintained outside a specialised laboratory.

### 11.1. Cleaning

If necessary, MicroSync can be cleaned using a damp cloth and a non-aggressive detergent. Do not use solvents such as trielene, acetone or benzene or any that are aggressive. Do not submerge the synchronizer in water or other liquids. Carefully remove any sand on it, blowing it away before wiping the surface. Dry the device thoroughly with a dry cloth if it is wet before putting it back, making sure that no wetness remains inside the connectors. To remove any wetness from the connectors, let it drain off and then blow away the remaining humidity.



**ALWAYS DISCONNECT ANY EXTERNAL POWER SUPPLY BEFORE CLEANING.**

### 11.2. Ambient conditions

MicroSync has been tested in the most varied conditions of use. The operational temperature range is between  $-20\text{ }^{\circ}\text{C}$  and  $+70\text{ }^{\circ}\text{C}$  with uncondensed humidity from 0 to 90%. Outside this range the device should not be used.

The storage range is from  $-50\text{ }^{\circ}\text{C}$  to  $+100\text{ }^{\circ}\text{C}$ . When the device has been stored outside the temperature range for use, wait for a few hours for it to return within the operational temperature range.

### 11.3. Attention

MicroSync has been designed for use exclusively in the sports sector. MicroSync is resistant if sprayed with water but is not waterproof.



**IF USED OUTDOORS, ONLY USE THE BUILT-IN BATTERIES OR A STANDARD BATTERY. DO NOT USE THE MAINS POWER SUPPLY.**

## 12. TECHNICAL DATA

<b>Weight</b>	250 g
<b>Dimensions</b>	120 x 65 x 40 mm (l x d x h)
<b>GPS time base</b>	GPS module always on with resynchronization on PPS signal (Pulse Per Second) every second. Synchronization signal precision $\pm 1 \mu\text{s}$
<b>Internal time base</b>	12.8 MHz Quartz, stability $\pm 1\text{ppm}$ between $-20^\circ$ and $+70^\circ\text{C}$
<b>Internal base precision</b>	$\pm 0.0864$ s/day for external temperatures between $-20^\circ$ and $+70^\circ\text{C}$
<b>Display</b>	<ul style="list-style-type: none"> <li>• Backlit alphanumeric display, 2 lines of 16 characters each character size: 5x3 mm</li> <li>• Low battery and external power supply LED indicator</li> </ul>
<b>Operating temperature</b>	$-20^\circ / +70^\circ\text{C}$
<b>Power supply</b>	Built-in Li-ion batteries; functioning also with c.c. 9~20V external power supply
<b>Battery recharge</b>	Built-in smart recharge device
<b>Autonomy</b>	> 48 hours
<b>Processor</b>	16-bit C-MOS microprocessor
<b>Keyboard</b>	<ul style="list-style-type: none"> <li>• Keyboard with waterproof film cover</li> <li>• 1 ON/OFF key</li> <li>• 1 ENTER key</li> <li>• 2 arrow keys for input and selection of configuration menu</li> </ul>
<b>Connections</b>	<ul style="list-style-type: none"> <li>• Output for synchronization on 4mm NO green and black banana plugs (input if the device must be synchronized for only internal base function and not GPS function)</li> <li>• RS 232 serial input/output for connection to REI2 stopwatch</li> <li>• Possibility of using the serial as standard NMEA protocol output</li> <li>• Jack power supply input</li> </ul>

### 13. Change history

The following table summarises the main changes made to this document.

<b>Document version</b>	<b>Chapter</b>	<b>Page</b>	<b>Intervention description</b>
1.00			First version of this manual.

## Copyright

Copyright © 2009 by Microgate s.r.l.  
All rights reserved

No part of this document or of any of the individual manuals may be copied or reproduced without the express written authorisation of Microgate s.r.l.

All the marks or names of products mentioned in this document or in the individual manuals are or may be registered marks belonging to the individual firms.

Microgate, REI 2, REI, RaceTime, MicroTab,  $\mu$ Tab, MicroGraph,  $\mu$ Graph, MicroBeep,  $\mu$ Beep, Uploader, Microrun, MicroLink,  $\mu$ Flasher, LinkPod, LinkGate, LinkGate encoder, LinkGate decoder, EncRadio, DecRadio, Polifemo, MicroSem,  $\mu$ Sem, MicroSync and  $\mu$ Sync are registered marks of Microgate s.r.l. or of licensed users.

Microgate s.r.l. reserves the right to modify the products described in this document and/or in the relative manuals without notice.

### **Microgate S.r.l.**

Via Stradivari, 4  
39100 BOLZANO  
ITALY

Tel. +39 0471 501532 - Fax +39 0471 501524

[info@microgate.it](mailto:info@microgate.it)

[www.microgate.it](http://www.microgate.it)